

PRODUCT SPECIFICATIONS

CSVF30S Vent Free Gas Stove



LOVE AT FIRST LIGHT



CSVF Series
Vent Free Gas Stove

ACTUAL DIMENSIONS

Actual size: 26-3/4" W x 28-1/2" H x 19-3/4" D (23-3/4" D with heat shield)
(680 mm x 724 mm x 502 mm) (603 mm D with heat shield)

STANDARD FEATURES

- Available in Graphite and Enamel Brown
- Millivolt with on/off switch and variable flame height control
- Flexible connector with on/off valve included
- No venting required for ease of installation
- Consumer friendly deluxe control panel

FIELD INSTALLED ACCESSORIES

- Warming Shelves, available in Graphite and Enamel Brown
- Triple Play Burner System with exclusive triple effect technology
- Variable thermostat controlled forced air blower (135 cfm) - BLOTS
- Ambient Technologies™ Remote Controls and Thermostats

TECHNICAL INFORMATION

- Maximum BTU Input: 32,000 BTU/hr
- Thermal Efficiency: 99.9%
- Approximate Heating Area: 1,500 sq ft
- CSA Design Certified

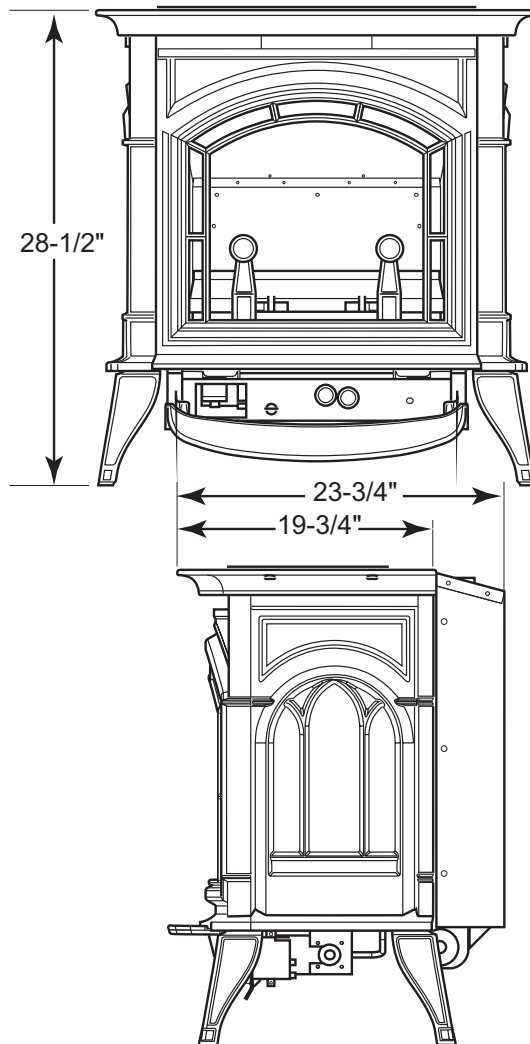
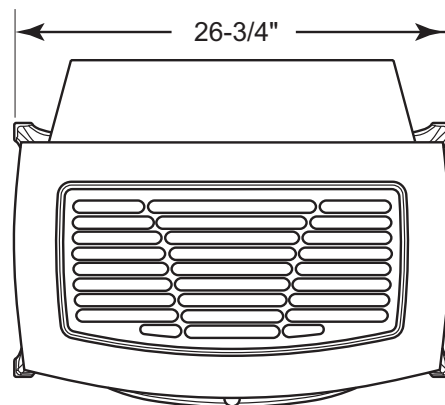

149 Cleveland Drive, Paris, Kentucky 40361
www.monessenhearth.com

To avoid personal injury or property damage, the product described by this brochure must be installed, operated and maintained in strict compliance with the instructions packaged with the product and all applicable building or fire codes. Contact local building or fire officials about restrictions and installation inspection requirements. All photographs and drawings on this brochure are for illustrative purposes only and are not intended for, nor should they be used as a substitute for the instructions packaged with the unit. Appearance and specifications of the product are subject to change without notice. 1215v2 © 2015 Hearth & Home Technologies